

Accurate, Repeatable Weighing for Suspended Hoppers and Vessels



Hopper and Vessel Weighing

SWS310 tension weigh modules are easy to install in a variety of industrial applications. They adapt to any suspended hopper or vessel to provide accurate weighing.



Load Cells

Model SLS410 nickel-plated tension load cells provide exceptional weighing accuracy in a wide range of process weighing applications.



Suspension Hardware

Each weigh module is equipped with a pair of clevis and rod assemblies that are designed to measure only vertical loads and restrain the vessel from moving. The zinc-plated carbon steel hardware is strong enough to support a vessel safely.



Electrical Isolation

The mounting hardware includes a bonding strap, lined bearings, and nylon washers to reduce the risk of electrical damage. The bonding strap helps to protect the load cell by shunting electrical currents directly from the top clevis to the bottom clevis, instead of through the load cell.



SWS310 Tension Weigh Module with SLS410 Load Cell

Tension weigh modules enable you to convert a suspended hopper or vessel into a scale. The mounting hardware is durable enough to withstand harsh industrial environments and support the vessel safely. The clevis and rod assemblies compensate for slight misalignment to help provide accurate and repeatable weighing.

- Nickel-plated alloy tool steel load cells
- Zinc-plated carbon steel mounting hardware
- For non-hazardous area applications

SWS310 / SLS410 Weigh Module Specifications

Weigh Module Parameter	Unit of Measure	Specification					
Model No.		SWS310					
Rated Capacity (R.C.)	kg	50 100	250 500 1000	2500 5000	7500		
	lb	50 100 200 300	500 750 1000 1500 2000 3000	5000 10,000		15,000	20,000
Load Limit, Safe ¹	%R.C.	150					
Weight (including load cell)	kg (lb)	0.73 (1.6)	1.95 (4.3)	5.4 (12)	11.7 (25.8)	16.5 (36.4)	21 (46.4)
Material		Zinc-plated carbon steel					

Load Cell Parameter	Unit of Measure	Specification							
Model No.		SLS410							
Rated Capacity (R.C.)	kg		50 100	250 500	1000	2500	5000	7500	
	lb	50 100	200 300	500 750 1000 1500	2000	3000 5000	10,000	15,000	20,000
Rated Output	mV/V @ R.C.	3.000 ± 0.25%							
Zero Load Output	%R.C.	1							
Combined Error ²	%R.C.	≤ 0.03							
Repeatability Error	%A.L. ³	≤ 0.01							
Creep, 30 Minutes	%A.L.	≤ 0.03							
Temperature Effect on	Min. Dead Load Output	%R.C./°C (.../°F) ≤ 0.0027 (0.0015)							
	Sensitivity	%A.L./°C (.../°F) ≤ 0.0014 (0.0008)							
Temperature Range	Compensated	°C (°F) -10 to +40 (+14 to +104)							
	Operating	°C (°F) -35 to +65 (-30 to +150)							
	Safe Storage	°C (°F) -35 to +85 (-30 to +185)							
Excitation Voltage	Recommended	V AC/DC 10							
	Maximum	V AC/DC 18							
Terminal Resistance	Excitation	Ω 430 ± 60							
	Output	Ω 350 ± 3.5							
Insulation Resistance @50VDC	MΩ	> 5000							
Breakdown Voltage	V AC	> 500							
Material	Spring Element	Nickel-plated alloy tool steel							
	Type	Potted							
Protection	IP Rating	IP67							
	NEMA Rating	NEMA 6							
Load Limit	Safe	%R.C. 150							
	Ultimate	%R.C. 300							
Safe Dynamic Load	%R.C.	70							
Fatigue Life	cycles @R.C.	1,000,000							
Deflection @ R.C., Nominal	mm (in)	0.18 (0.007)	0.23 (0.009)	0.5 (0.020)	0.6 (0.024)	0.64 (0.025)	0.53 (0.021)		
Weight	kg (lb)	0.65 (1.4)	0.7 (1.6)	0.9 (2.0)	1.6 (3.4)	1.8 (4.0)	3 (6.6)	7.3 (16.1)	
Cable Length	m (ft)	6 (19.7)							
Overload Protection		no							

¹ Maximum tensile load that can be applied.

² Error due to the combined effect of non-linearity and hysteresis.

³ A.L. = Applied Load.

SWS310 Weigh Module Dimensions

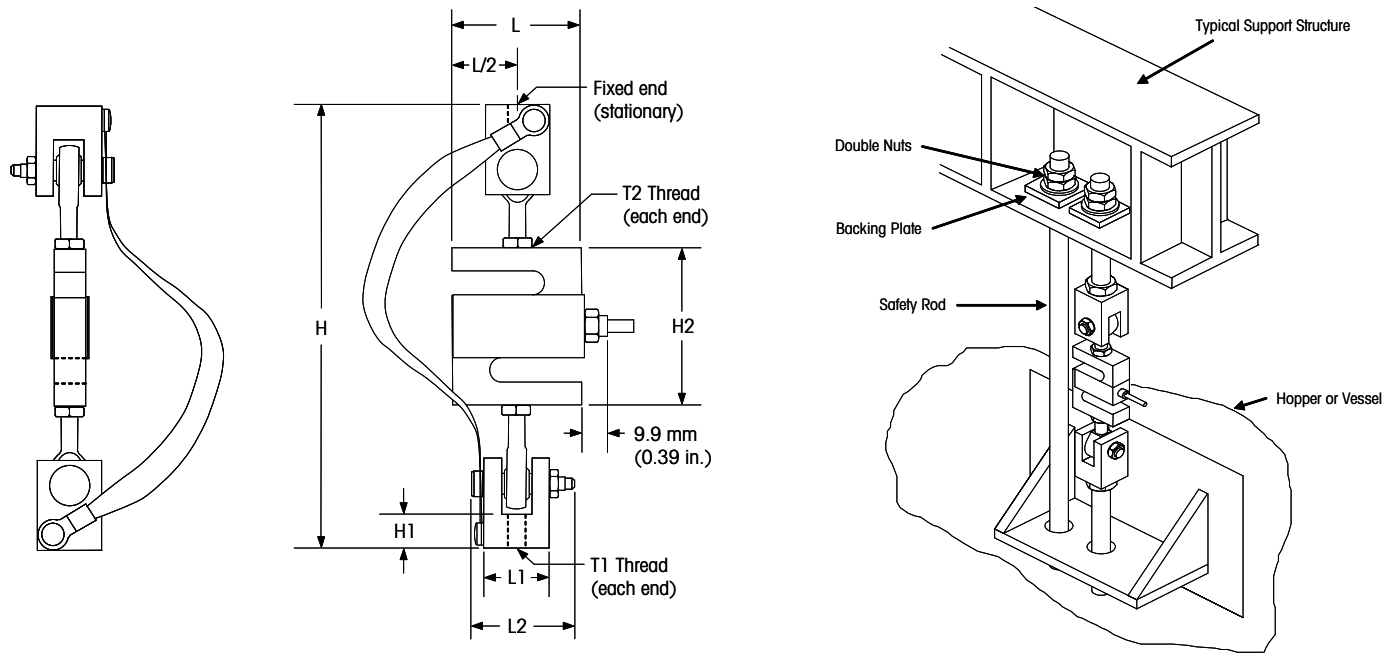

Shoulder screw/lock nut assembly as shown is typical for all assemblies except 7500 kg. That capacity uses a clevis/hitch pin in place of the shoulder screw.

Note: Always use a secondary means of support such as safety chains or rods to prevent the hopper or vessel from falling due to component failure.

Capacity	H	H1	H2	L Max	L1	L2	T1	T2
50-300 lb	173.2 mm 6.82 in.	14.2 mm 0.56 in.	63.5 mm 2.50 in.	50.8 mm 2.00 in.	25.4 mm 1.00 in.	39.6 mm 1.56 in.	3/8-16 UNC	1/4-28 UNF
500-2000 lb	255.8 mm 10.07 in.	26.2 mm 1.03 in.	63.5 mm 2.50 in.	50.8 mm 2.00 in.	38.1 mm 1.50 in.	62.0 mm 2.44 in.	5/8-11 UNC	1/2-20 UNF
3000 lb	283.7 mm 11.17 in.	26.2 mm 1.03 in.	101.6 mm 4.00 in.	76.2 mm 3.00 in.	38.1 mm 1.50 in.	62.0 mm 2.44 in.	5/8-11 UNC	1/2-20 UNF
5000-10,000 lb	331.5 mm 13.05 in.	33.3 mm 1.31 in.	101.6 mm 4.00 in.	76.2 mm 3.00 in.	57.2 mm 2.25 in.	92.2 mm 3.63 in.	1-8 UNC	3/4-16 UNF
15,000 lb	465.1 mm 18.31 in.	50.8 mm 2.00 in.	139.7 mm 5.50 in.	101.6 mm 4.00 in.	88.9 mm 3.50 in.	130.3 mm 5.13 in.	1.375-6 UNC	1-14 UNS
20,000 lb	496.8 mm 19.56 in.	50.8 mm 2.00 in.	177.8 mm 7.00 in.	127.0 mm 5.00 in.	88.9 mm 3.50 in.	130.3 mm 5.13 in.	1.375-6 UNC	1.25-12 UNF
50-100 kg	177.2 mm 6.98 in.	12.5 mm 0.49 in.	63.5 mm 2.50 in.	50.8 mm 2.00 in.	25.4 mm 1.00 in.	41.5 mm 1.63 in.	M8x1.25	M8x1.25
250-1000 kg	237.2 mm 9.34 in.	26.5 mm 1.04 in.	63.5 mm 2.50 in.	50.8 mm 2.00 in.	38.1 mm 1.50 in.	64.0 mm 2.52 in.	M12x1.75	M12x1.75
2500 kg	340.1 mm 13.39 in.	32.0 mm 1.26 in.	101.6 mm 4.00 in.	76.2 mm 3.00 in.	57.2 mm 2.25 in.	96.0 mm 3.78 in.	M27x3	M20x1.5
5000 kg	330.0 mm 12.99 in.	32.0 mm 1.26 in.	101.6 mm 4.00 in.	76.2 mm 3.00 in.	57.2 mm 2.25 in.	96.0 mm 3.78 in.	M27x3	M20x1.5
7500 kg	410.7 mm 16.17 in.	40.0 mm 1.57 in.	139.7 mm 5.50 in.	101.6 mm 4.00 in.	76.2 mm 3.00 in.	95.0 mm 3.74 in.	M30x3.5	M24x2

SLS410 Load Cell Cable Colors

Color	Function
Red	+ Excitation
Black	- Excitation
Green	+ Signal
White	- Signal
Bare	Shield

SWS310 Ordering Information

Description	Item No.
SWS310 Weigh Module, 50 lb (with load cell)	61041096
SWS310 Weigh Module, 100 lb (with load cell)	61041097
SWS310 Weigh Module, 200 lb (with load cell)	61041098
SWS310 Weigh Module, 300 lb (with load cell)	61041099
SWS310 Weigh Module, 500 lb (with load cell)	61041100
SWS310 Weigh Module, 750 lb (with load cell)	61041101
SWS310 Weigh Module, 1000 lb (with load cell)	61041102
SWS310 Weigh Module, 1500 lb (with load cell)	61041103
SWS310 Weigh Module, 2000 lb (with load cell)	61041104
SWS310 Weigh Module, 3000 lb (with load cell)	61041105
SWS310 Weigh Module, 5000 lb (with load cell)	61041106
SWS310 Weigh Module, 10000 lb (with load cell)	61041107
SWS310 Weigh Module, 15000 lb (with load cell)	61041108
SWS310 Weigh Module, 20000 lb (with load cell)	61041109
SWS310 Weigh Module, 50 kg (with load cell)	61041110
SWS310 Weigh Module, 100 kg (with load cell)	61041111
SWS310 Weigh Module, 250 kg (with load cell)	61041112
SWS310 Weigh Module, 500 kg (with load cell)	61041113
SWS310 Weigh Module, 1000 kg (with load cell)	61041114
SWS310 Weigh Module, 2500 kg (with load cell)	61041115
SWS310 Weigh Module, 5000 kg (with load cell)	61041116
SWS310 Weigh Module, 7500 kg (with load cell)	61041117

SLS410 Ordering Information

Description	Item No.
SLS410 Load Cell, 50 lb	61041049
SLS410 Load Cell, 100 lb	61041050
SLS410 Load Cell, 200 lb	61041051
SLS410 Load Cell, 300 lb	61041052
SLS410 Load Cell, 500 lb	61041053
SLS410 Load Cell, 750 lb	61041054
SLS410 Load Cell, 1000 lb	61041055
SLS410 Load Cell, 1500 lb	61041056
SLS410 Load Cell, 2000 lb	61041057
SLS410 Load Cell, 3000 lb	61041058
SLS410 Load Cell, 5000 lb	61041059
SLS410 Load Cell, 10000 lb	61041060
SLS410 Load Cell, 15000 lb	61040280
SLS410 Load Cell, 20000 lb	61040281
SLS410 Load Cell, 50 kg	61040291
SLS410 Load Cell, 100 kg	61040292
SLS410 Load Cell, 250 kg	61040293
SLS410 Load Cell, 500 kg	61040294
SLS410 Load Cell, 1000 kg	61040295
SLS410 Load Cell, 2500 kg	61040296
SLS410 Load Cell, 5000 kg	61040297
SLS410 Load Cell, 7500 kg	61040298



METTLER TOLEDO Service

Our extensive service network is among the best in the world and ensures maximum availability and service life of your product.

Weigh-Connect-Control-Comply

METTLER TOLEDO embeds intelligence into weighing applications. Our industry leading scale electronics enable users to integrate their gravimetric measurement with applications running on PCs, PLCs, or DCS systems. Our products are designed specifically for industries subject to regulatory controls, such as pharmaceutical, chemical, food and beverage, and has been confirmed by multiple global agency standards including UL, CE, NTEP, and OIML.

www.mt.com/weighmodule

For more information

Mettler-Toledo, LLC

1900 Polaris Parkway
Columbus, Ohio 43240
Tel. (800) 786-0038
(614) 438-4511
Fax (614) 438-4900

Specifications subject to change without notice.

© 2012 Mettler-Toledo, LLC

09/2012

I06-TH03461.0E